



**Parts List for 3.25
Center Distance Style
"QH Plus"**

Regal Power Transmission Solutions

Regal Beloit America, Inc.
7120 New Buffington Road
Florence, KY 41042
Application Engineering: 800 626 2093
www.RegalPTS.com

FORM

**9132E
Revised
July 2016**

⚠ WARNING

- Read and follow all instructions carefully.
- Disconnect and lock-out power before installation and maintenance. Working on or near energized equipment can result in severe injury or death.
- Do not operate equipment without guards in place. Exposed equipment can result in severe injury or death.

⚠ CAUTION

- Periodic inspections should be performed. Failure to perform proper maintenance can result in premature product failure and personal injury.

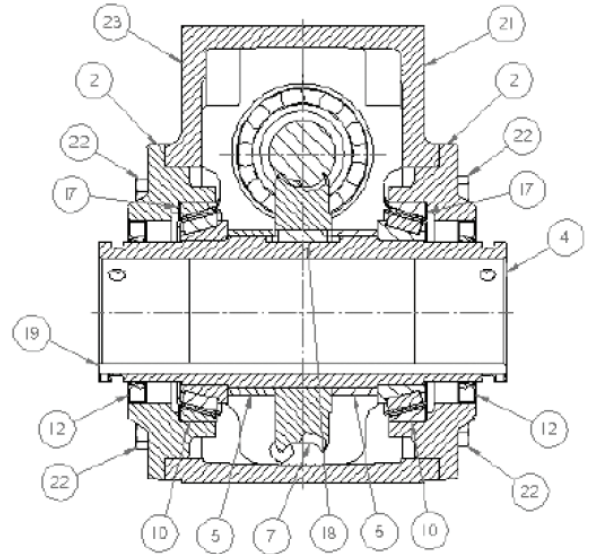
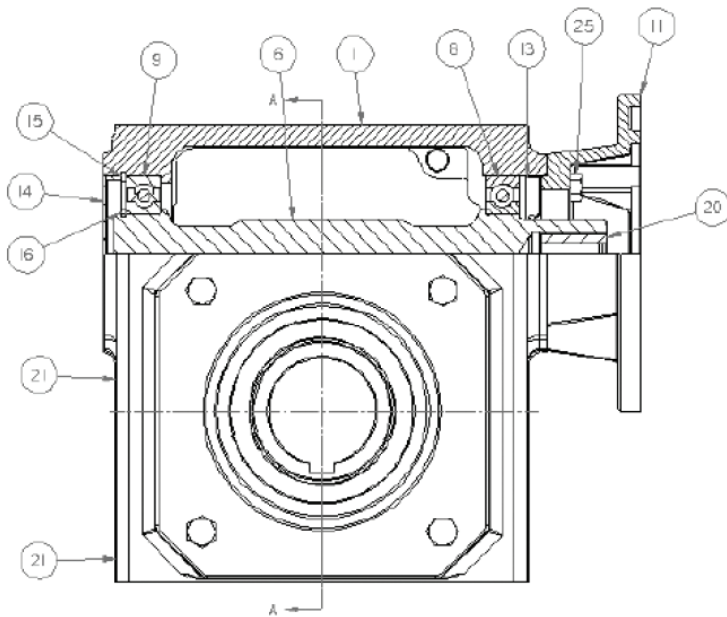

Item No.	Description	Part No.	No. Req'd	Additional Description
1	Housing	KI2002	1	
2	Bearing Carrier – Open	KI2007	2	
3				
4	Output Shaft – Quill/Hollow	KI0101	1	
5	Spacer – Gear	KI0016	2	
6	Worm – 10:1 Ratio – 5/8" Bore	KI2142	1	
	Worm – 15:1 Ratio – 5/8" Bore	KI2143		
	Worm – 20:1 Ratio – 5/8" Bore	KI2144		
	Worm – 25:1 Ratio – 5/8" Bore	KI2145		
	Worm – 30:1 Ratio – 5/8" Bore	KI2146		
	Worm – 40:1 Ratio – 5/8" Bore	KI2147		
	Worm – 50:1 Ratio – 5/8" Bore	KI2148		
	Worm – 60:1 Ratio – 5/8" Bore	KI2149		
	Worm – 10:1 Ratio – 7/8" Bore	KI2152		
	Worm – 15:1 Ratio – 7/8" Bore	KI2153		
	Worm – 20:1 Ratio – 7/8" Bore	KI2154		
	Worm – 25:1 Ratio – 7/8" Bore	KI2155		
	Worm – 30:1 Ratio – 7/8" Bore	KI2156		
	Worm – 40:1 Ratio – 7/8" Bore	KI2157		
	Worm – 50:1 Ratio – 7/8" Bore	KI2158		
	Worm – 60:1 Ratio – 7/8" Bore	KI2159		
	Worm – 10:1 Ratio – 1 1/8" Bore	KI2162		
	Worm – 15:1 Ratio – 1 1/8" Bore	KI2163		
	Worm – 20:1 Ratio – 1 1/8" Bore	KI2164		
	Worm – 25:1 Ratio – 1 1/8" Bore	KI2165		
	Worm – 30:1 Ratio – 1 1/8" Bore	KI2166		
	Worm – 40:1 Ratio – 1 1/8" Bore	KI1267		
	Worm – 50:1 Ratio – 1 1/8" Bore	KI1268		
	Worm – 60:1 Ratio – 1 1/8" Bore	KI2169		
7	Worm Wheel – 10:1 Ratio	KI1265	1	
	Worm Wheel – 15:1 Ratio	KI1266		
	Worm Wheel – 20:1 Ratio	KI1267		
	Worm Wheel – 25:1 Ratio	KI0268		
	Worm Wheel – 30:1 Ratio	KI1269		
	Worm Wheel – 40:1 Ratio	KI1270		
	Worm Wheel – 50:1 Ratio	KI1271		
	Worm Wheel – 60:1 Ratio	KI1272		
	Bearing – Input – Front – 56C	FF5013	1	6208 RUCE
	Bearing – Input – Front – 143/145TC	FF5013		6208 RUCE
	Bearing – Input – Front – 182/184TC	FF3130		6010 U
9	Bearing – Input – Back	FF5013	1	6208 RUCE
10	Bearing – Output	FF0359	2	32015X
11	Motor Flange – 56C	KG2009	1	
	Motor Flange – 143/145TC	KG2009		
	Motor Flange – 182/184TC	KG1142		
12	Seal – Output	FG0340	2	2.875 x 3.751 x 0.375
13	Seal – Input – 56C	FG2017	1	1.375 x 3.150 x 0.375
	Seal – Input – 143/145TC	FG2017		1.375 x 3.150 x 0.375
	Seal – Input – 182/184TC	FG1690		CR 18981
14	Bore Plug – Input	FG3114	1	80mm x 9mm
15	Snap Ring – Housing – 56C	FI1242	1	N5000 - 315
16	Snap Ring – Worm	FI1061	1	HD 5160 – 156
17	Shims	FI0976	3	0.003 Thick
		FI0977	3	0.007 Thick
		FI0978	2	0.010 Thick
		FI0979	1	0.025 Thick
18	Key – Worm Wheel	FH0016	1	¼ SQ x 1
19	Key – Output	FH0351	1	½ x 7/16 x 8 1/4
20	Quill Liner – 56C	FA0574	1	
	Quill Liner – 143/145TC	FA0575		
	Quill Liner – 182/184TC	FA0576		
21	Oil Plug	FK0504	4	SOC HD PP 1/4
22	Cap Screws	FJ8002-H100	8	HX HD CS 3/8 – 16 x 1 P5
23	Breather	FJ9879	1	
		FK3037	1	
24				
25	Motor Flange Capscrews	FJ8104-G100	4	SOC HD CS 5/16 – 18 x 1 P8
	Motor Capscrews – 56C	FJ8002-H100	4	HX HD CS 3/8 – 16 x 1 P5
	Motor Capscrews – 143/145TC	FJ8002-H100		HX HD CS 3/8 – 16 x 1 P5
	Motor Capscrews – 182/184TC	FJ8002-K104		HX HD CS ½ - 13 x 1 ¼ P5
	Motor Lockwashers – 56C	FJ8712-H	4	LW-S 3/8 .38/.68/.10P
	Motor Lockwashers – 143/145TC	FJ8712-H		LW-S 3/8 .38/.68/.10P
	Motor Lockwashers – 182/184TC	FJ8712-K		LW-S ½ .51/.87/.13P
	Set Screw – Quill – Keyway	FJ8201-E04	2	SSSCUP #10 – 32 x ¼ P5
	Set Screw – Quill	FJ8202-H06	4	SSSCUP 3/8 – 16 x 3/8 P5
	Oil	FU0496	81 oz.	Polyglycol 460
	Nameplate	FN0378	1	

