

Ratio Options	1
2PD06	
1.67 Dec.	
1.57 Dec.	
1.48 Dec.	
1.40 Dec.	
1.32 Dec.	
1.25 Dec.	
1.18 Dec.	
1.06 Dec.	
1:1	
1.06 Inc.	
1.18 Inc.	
1.25 Inc.	
1.32 Inc.	
1.40 Inc.	
1.48 Inc.	
1.57 Inc.	
1.67 Inc.	

SAE Clutch Housing Options				2
SAE No.	Dim. A	Dim. B	Bolt Size & Qty.	
1	20.875	20.125	7/16-14 (12)	
2	18.375	17.625	3/8-16 (12)	
3	16.875	16.125	3/8-16 (12)	

SAE Clutch Options						3
Clutch No.	Dim. C	Dim. D	Dim. F	Dim. G	Bolt Size & Qty.	
SP214	18.375	17.250	11.12	1.00	(8) 17/32	
SP211	13.875	13.125	8.25	1.56	(8) 13/32	
SP114	18.375	17.250	8.25	1.00	(8) 17/32	
C111	13.875	13.125	8.25	1.56	(8) 13/32	
C110	12.375	11.625	8.25	2.12	(8) 13/32	

Pilot Bearing	
Std. Bearing No.	Dim. E
6407 ZZ	3.9370
6307 ZZ	3.1496
6207 ZZ	2.8346

SAE Pump Pad Adapters					5	6
SAE Size	Bolt Size & Qty.	Bolt Circle	Pilot Dia.	Dim. H		
A	3/8-16 (2)	4.187	3.25	6.13		
B	1/2-13 (2)	5.750	4.00	6.13		
B	1/2-13 (4)	5.000	4.00	6.13		
C	5/8-11 (2)	7.125	5.00	6.13		
C	1/2-13 (4)	6.375	5.00	6.13		
D	3/4-10 (4)	9.000	6.00	6.13		
D2	3/4-10 (2)	9.000	6.00	6.25		
E	3/4-10 (4)	12.500	6.50	6.25		
F	1.00-8 (4)	13.781	7.00	6.63		

SAE Pump Spline Adapters			7	8
SAE Size	Teeth	& Pitch		
A	9T-16/32			
B	13T-16/32			
BB	15T-16/32			
C	14T-12/24			
CC	17T-12/24			
D	13T-8/16			
F	15T-8/16			
21	21T-16/32			
23	23T-16/32			
27	27T-16/32			

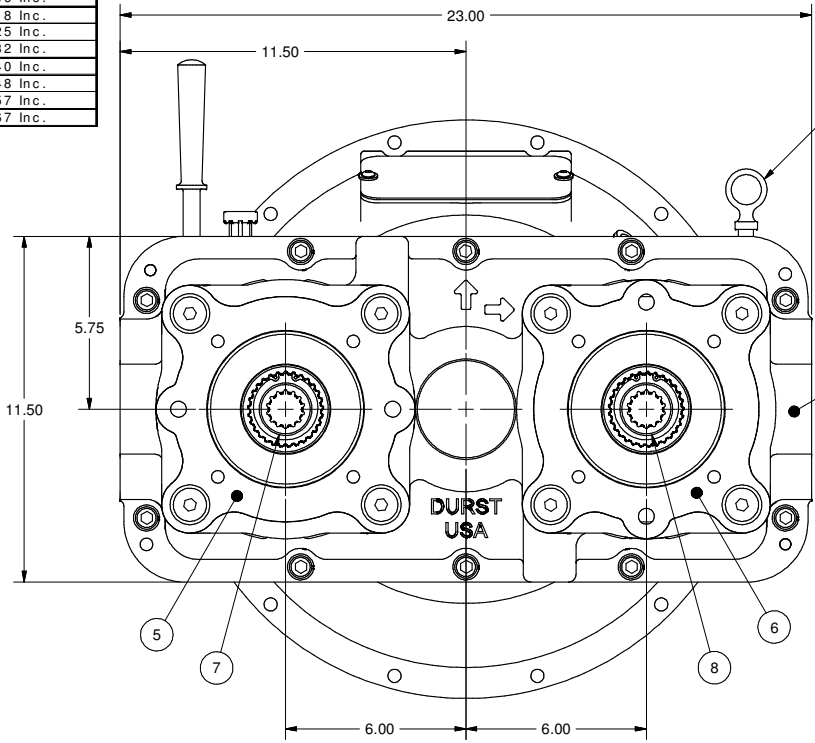

9 SEE MODEL DESCRIPTION FOR DIPSTICK LOCATION

5/8-11 UNC X 1.00 DEEP (4) PLCS. BOTH SIDES

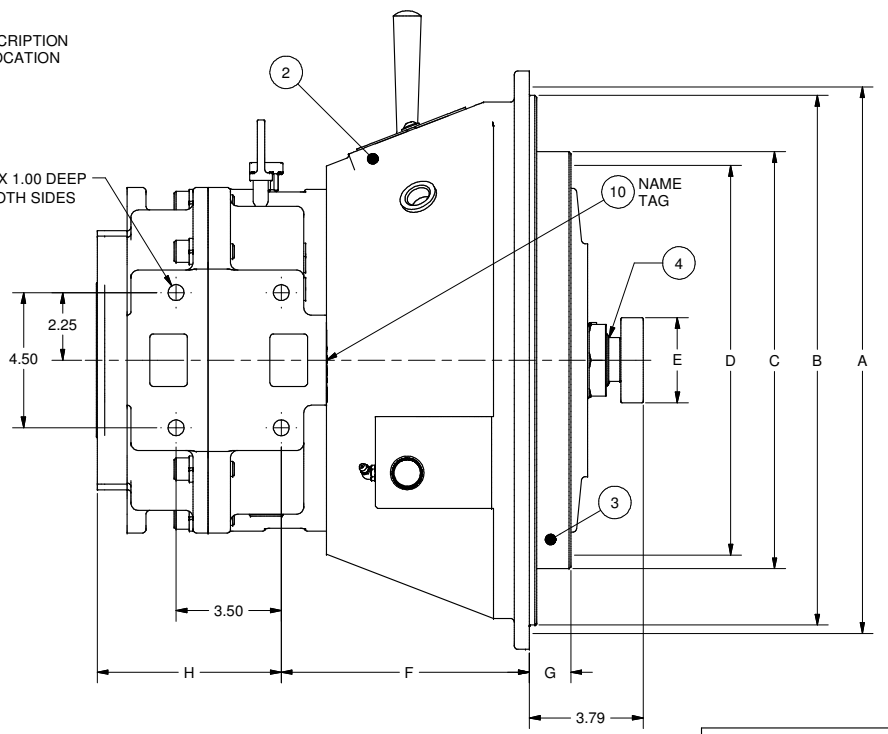

- NOTE:
- REFER TO ASSEMBLY BOOK FOR ADAPTER MOD DRAWINGS.
 - LUBRICATE ALL ORINGS PRIOR TO INSTALLATION.
 - APPLY SILVER STREAK #200S TO EXTERNAL SPLINES OF INPUT SHAFT.
 - USE LOCTITE 609 WHEN INSTALLING EXP. PLUG, P/N 012043.
 - USE LOCTITE 609 WHEN INSTALLING DIPSTICK, AND DIPSTICK HOLE PLUG, P/N 012326.
 - DO NOT USE LOCTITE ON PUMP PAD SCREWS.
 - TIGHTEN 1/2" SCREWS: 105 FT.LBS.
 - TIGHTEN 5/8" SCREWS: 210 FT.LBS.
 - OIL MUST MEET API GL-5 SPEC: 80W90, EP90 OR EQUIVALENT.
 - WHEN ORDERING PARTS REFER TO THE DURST SERVICE MANUAL.

PATENT NO. 7,152,711

CAUTION
Always insure that your powertrain is free of torsional vibrations. DURST is not responsible for damage or failure due to unaddressed torsional vibrations.

REV	W/O. NO.	ZONE	DESCRIPTION	BY	DATE
6	30214		DIM "F" FOR SP214 WAS 10.77	WEM	9/21/10
5	27419		ADDED 1.06 RATIOS AND PATENT NO.	WEM	5/22/07
4	25834		UPDATED SPLINE CHART	NJS	11/05/04
3	25757		ADDED 1.25 INC AND DEC RATIOS	NJS	10/08/04
2	25724		UPDATED ITEM NUMBERS	NJS	9/24/04
1	24560		RELEASED TO PRODUCTION	WEM	9/3/04

ALL DIMENSIONS IN INCHES UNLESS OTHERWISE SPECIFIED: CASTINGS ALLOW .12 FINISH STOCK ON MACHINING SURFACES. FILLETS AND RADI: 12 MAX. MACHINING TOLERANCES: X & .000 FRAC & 1/64 XX & .010 ANGLE & 30° 15°/FINISH

THIS PRINT IS CONFIDENTIAL AND IS THE PROPERTY OF DURST DIV. REGAL-BELT CORP. THIS PRINT SHALL NOT BE USED, COPIED OR REPRODUCED IN WHOLE OR IN PART, NOR SHALL THE CONTENTS BE REVEALED IN ANY MANNER TO ANYONE UNLESS WRITTEN PERMISSION IS OBTAINED FROM DURST DIV. REGAL-BELT CORP.

MATERIAL: _____

SCALE: 1/2:1

THIRD ANGLE PROJECT

TITLE: 2PD06 CLUTCH CHARTED DRAWING

PART NO: 2PD06C

SIZE: D

AMFP SEQUENCE NO. _____

DURST
DIVISION OF REGAL-BELT CORP.
P.O. BOX 298
BELLEVILLE, MISSOURI 63811

DRAWING T.O.P. 1